

BACHELOR OF TECHNOLOGY (C.B.C.S.) (2020 COURSE)
B.Tech.Sem - V Robotics & Automation Engineering : WINTER- 2022
SUBJECT : ROBOT KINEMATICS & DYNAMICS

Day : Tuesday

Time : 02:30 PM-05:30 PM

Date : 06-12-2022

W-24795-2022

Max. Marks : 60

N. B. :

- 1) All questions are **COMPULSORY**.
- 2) Figures to the right indicate **FULL** marks.
- 3) Draw neat and labelled diagrams **WHEREVER** necessary.
- 4) Use of non-programmable calculator is **ALLOWED**.
- 5) Assume suitable data, if necessary.

Q. 1 Explain with neat sketch different types of wheels used in robots. (10)

OR

Q. 1 Draw and explain types of robot configurations used for development of linkage mechanisms. (10)

Q. 2 a) Elaborate concept of Forward and Inverse Kinematics. (10)

b) A vector $V = 3i + 2j + 7k$ is rotated by 60° about the z - axes of the reference frame. It is then again rotated by 30° about the x - axes of the rotated frame. Find the rotation transformation.

OR

Q. 2 a) What is workspace? Discuss categories of workspace for serial manipulator. (10)

b) It is desired to determine the value to which the angles θ_1 and θ_2 must be set in order to achieve a certain point in space for manipulator as shown in fig. The length of joint - 1 is $L_1 = 14$ in and length of joint - 2 is $L_2 = 8$ in. The point 'P' which the robot must achieve is defined by co-ordinates $X = 15.7$ and $Y = 12.6$. Using inverse kinematic transformation method determine the angles θ_1 and θ_2 .

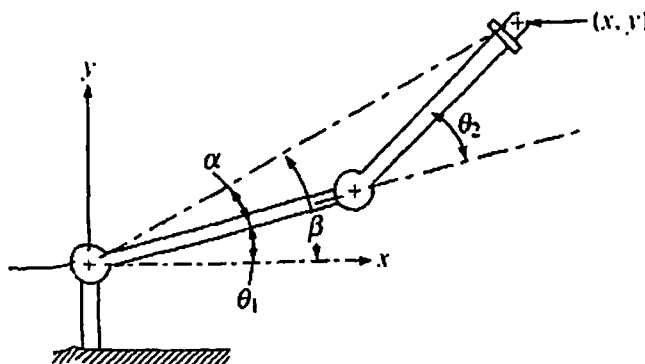

Q. 3 Write a short note on active and passive joints in parallel robot manipulator. (10)

OR

Q. 3 Explain the concept of reachable work space and dexterous work space with neat diagram. (10)

P. T. O.

- Q. 4 Write short note on: (10)
- Velocity propagation along the links of robot manipulator.
 - Computation of Singularities by Jacobian matrix.

OR

- Q. 4 For the 2-DOF planar arm shown in following figure, assuming both the (10)
links of unit length, determine
- configuration singularities
 - joint velocities in terms of endpoint velocities

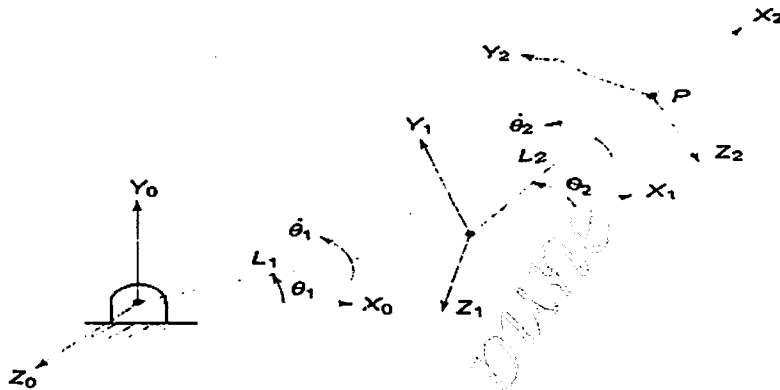

- Q. 5 Explain direct and inverse dynamics of robotic manipulator. (10)

OR

- Q. 5 Write a short note on recursive dynamics. (10)

- Q. 6
- State and explain different steps in trajectory planning. (10)
 - The second joint of SCARA manipulator is required to move from $\theta_2 = 30^\circ$ to 150° in 5 seconds. Find the cubic polynomial to generate the smooth trajectory for the joint. What is the maximum velocity and acceleration for this trajectory?

OR

- Q. 6 Draw a block diagram and explain the parameters involved in trajectory – (10)
planning problem. Also state and explain all the terminologies in trajectory
planning.

* * * * *