

OR

Q.2 A pictorial view of a bracket is given in Fig. Draw by first angle method of projection. (10)

- i) Sectional front view looking in direction X (section plane A-A)
- ii) Top View. Give necessary dimensions

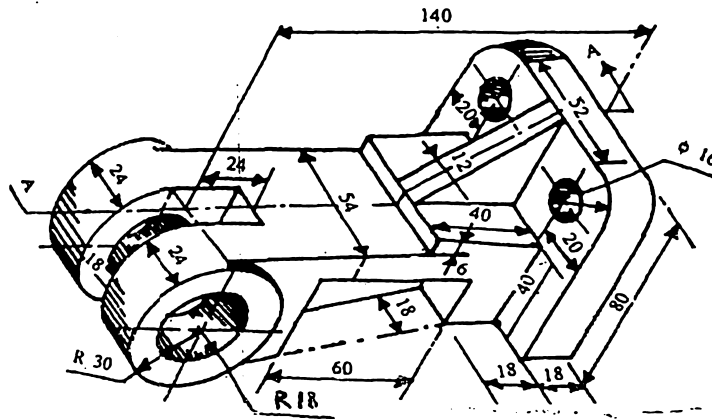

Q.3 For the object shown in figure draw an isometric view taking 'O' as origin. (10)

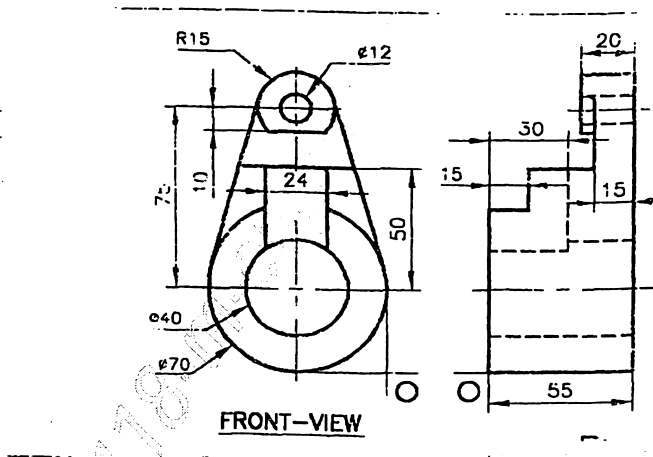

OR

Q.3 For the two views of the object shown below draw its isometric view. (10)

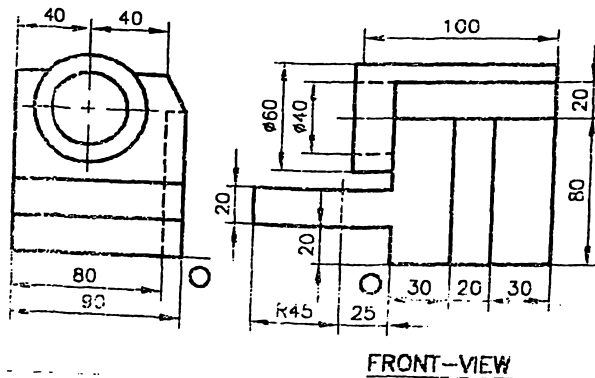

...2...

- Q.4** The end A of the line AB 105mm long is 20mm above HP and 35mm in front of VP. The elevation of the line is inclined at 45° . The VT is 35mm below HP. Draw the projection of line and find the inclination with the reference planes. Also locate the HT. (10)

OR

- Q.4** A line AB has its end point A 10mm above the HP. Distance of projectors between its ends A and B is 70mm. Distance of projectors between its traces is 110mm. The elevation of the line is inclined at 45° to the XY line and its plan is inclined at 30° to the XY line. Draw the projections of the line; find its true length, inclination with HP and inclination with VP. Also locate its traces. (10)

- Q.5** A rhombus ABCD has its diagonal AC = 80mm and BD = 50mm. The side AD of the plane is in HP and the plane makes an angle of 30° with the HP. Obtain the projections of the plane when side CD is in VP. Find inclination of the plane with VP. (10)

OR

- Q.5** Draw the projections of a circle of 60mm diameter resting in the HP on a point A on the circumference if the plate is inclined at 30° to HP and the diameter AB makes 35° with the VP. Also find the inclination of the plate with VP. (10)

- Q.6** A pentagonal pyramid of base 20mm and height 50mm has its triangular face in the VP with a shorter side inclined to the HP at 30° . Draw its projections. (10)

OR

- Q.6** A cone of base diameter 40mm and axis length 50mm is kept on the HP on its base. It is cut by an Auxiliary inclined plane inclined at 45° to the HP and passes through the point on the axis 30mm above the base. Draw front view, sectional T.V., sectional side view and true shape of the section. (10)

* * * * *