

B.Tech. SEM -V (Civil) 2014 Course (CBCS) : SUMMER - 2019

SUBJECT: STRUCTURAL DESIGN-I

Day: Thursday
Date: 09/05/2019

S-2019-2649

Time: 10.00 AM TO 02.00 PM
Max. Marks: 60

N.B:

- 1) All questions are **COMPULSORY**.
- 2) Figures to the right indicate **FULL** marks.
- 3) Assume suitable data if necessary.
- 4) Use of IS800, IS875, steel table and calculator is **ALLOWED**.

- Q.1 a) What is limit state design? Explain its design philosophy. (05)
- b) What are merits and demerits of steel structures? Explain along mechanical properties of structural steel. (05)

OR

- Q.1 Calculate wind load acting at each panel point for the truss with following data. (10)
- Span of truss- 24m, Height of Truss- 3m, Spacing of Purlins- 1.6m, spacing of truss - 5m, Eaves height -9m, Opening - 30%, Location- Delhi, Design life of truss- 50 yrs, $K_3 = 1$, Assume suitable Terrain category.

- Q.2 An ISA 200×200×12 is subjected to design axial force of 600kN. Design its connection with gusset plate using bolts. (10)

OR

- Q.2 A flat is welded with gusset plate using 10mm size fillet weld as shown in figure. Calculate the design strength of welded joint. (10)

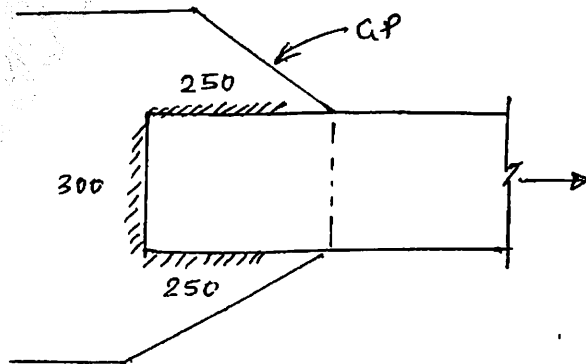

- Q.3 An ISA 200×200×16 is connected to gusset plate using 4 bolts of M16 in one row. Calculate its design strength in tension. (10)

OR

- Q.3 A truss member is subjected to design axial tension of 1000kN. Design suitable double angle section for this member. (10)

P.T.O.

- Q.4 A column of length 3m is fixed at one end and pinned at other end. An ISMB300 is used for this column. Calculate design capacity of this column in compression. (10)

OR

- Q.4 a) What are factors influencing design compression capacity? (05)
b) Find out buckling class of following sections. (05)

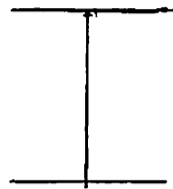

ISMB 400



ISMC 300



ISA 150 x 150 x 10

- Q.5 A Column is made up of two channel sections ISMC300 are placed face to face with clear spacing of 60mm between them. The column is subjected to design load of 1500kN. Length of column is 4m. Design suitable lacing system for this column. (10)

OR

- Q.5 For the above column sections in Q.5, Design suitable base for this column. (10)
Assume M25 Grade Concrete, SBC of Soil = 250kN/m².

- Q.6 a) What is curtailment of flange plate? Explain with suitable examples. (05)
b) What is web buckling and web crippling? Explain with suitable examples. (05)

OR

- Q.6 A simply supported beam of span 4m is subjected to an UDL of 50kN/m over whole span. The beam is laterally supported throughout the span. Only ISMB 300 is available at site. Design the beam using ISMB 300, provide extra flange plates if required. (10)

* * * * *