

BACHELOR OF TECHNOLOGY (C.B.C.S.) (2021-COURSE)
B. Tech. Sem - I MECHANICAL : WINTER- 2022
SUBJECT : STATICS & DYNAMICS

Day : Wednesday
 Date : 18-01-2023

W-24061-2022

Time : 10:00 AM-01:00 PM
 Max. Marks : 60

N.B.:

- 1) All questions are **COMPULSORY**.
- 2) Figure to the right indicate **FULL** marks.
- 3) Use of scientific non-programmable **CALCULATOR** is allowed.
- 4) Assume suitable data if necessary.

- Q.1 a) What are various types of loading acting on beam? (03)**
- b) Two identical roller each of weight 1500N are supported by an inclined plane (07)**
 and a vertical wall as shown in figure. Assuming smooth surfaces. Find the reactions induced at the points of contact A, B and C.

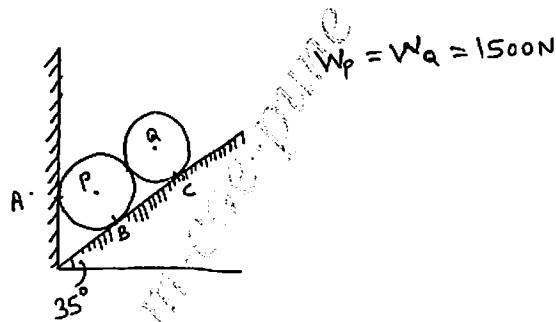

OR

- Q.1 a) State the varignon's theorem. (03)**
- b) Calculate the magnitude, direction and location of resultant force with respect (07)**
 to point A as shown in figure.

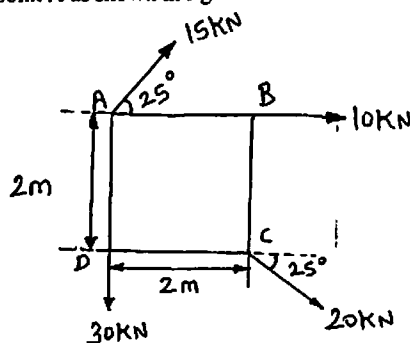

- Q.2 a) Define mechanical advantages and velocity ratio with its expression. (03)**
- b) State the law of static friction. A body of weight 500N is pulled up an inclined (07)**
 plane by a force of 330N. The inclination of the plane is 30° to the horizontal and force is applied parallel to plane. Determine the coefficient of friction.

P.T.O.

OR

- Q.2 a) Draw the sketch of semi-circle and right angle triangle and show the location of centroid of it. (03)
- b) Determine the moment of inertia about base AB of lamina as shown in figure. (07)

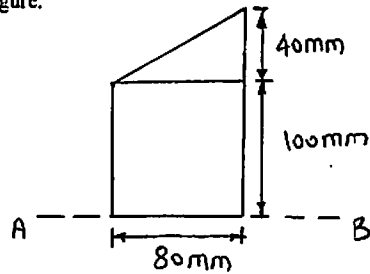

- Q.3 Find forces in all the members of the truss by using method of joint. Tabulate the result. (10)

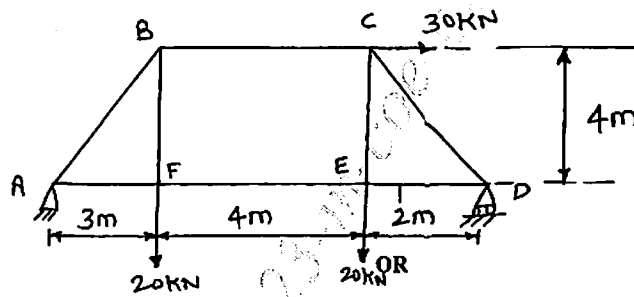

- Q.3 A cable ABCD supported at the ends A and D carries a vertical load "W" at B and a horizontal load of 150N at C as shown in figure. Determine the magnitude of the load "W" and the tensions in the segments AB, BC and CD of the cable. (10)

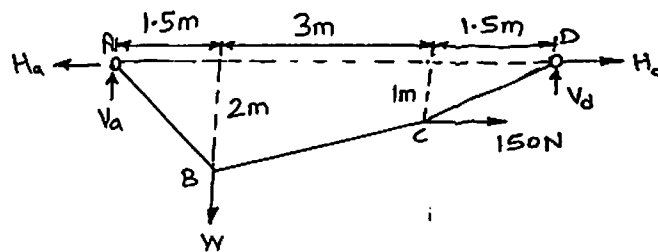

- Q.4 a) Derive the expression for maximum height for projection motion. (04)
- b) A burglar's car had a start with an acceleration of 2m/s^2 . A police vigilant party come after 5 sec and continued to chase the burglar's car with a uniform velocity of 20 m/sec. Find the time taken in which the police van will overtake the burglar's car. (06)

..2..

OR

- Q.4 a) A particle is projected at an angle of 30° with the horizontal. The horizontal range of the particle is 4 kilometer. (05)
Find: i) The velocity of projection.
ii) The maximum height attained by the projection.
- b) The x and y Co-ordinates of the position of a particle moving in curvilinear motion are defined by $x = 2 + 3t^2$ and $y = 3 + t^3$. Determine the particle's position, velocity and acceleration at $t = 3$ sec. (05)
- Q.5 After the block in figure has moved 10m from rest the constant force $F = 1.2$ KN is removed. Find the velocity of block when it returned to its initial position. Take $\mu_k = 0.2$ (10)

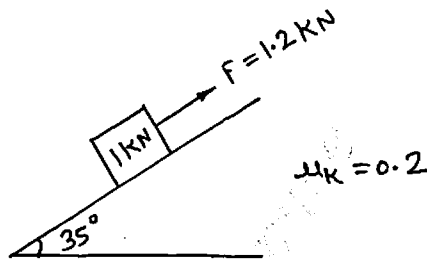

OR

- Q.5 Three perfectly elastic balls A, B and C of masses 4 kg, 8kg and 16kg move in the same direction with velocities of 8m/sec, 2m/sec and 1.5m/sec respectively. If the ball A impinges with the ball B, which in turn impinges with the ball C. Prove that the balls A and B will be brought to rest after the impact. (10)
- Q.6 a) Explain with neat sketch of combined footing. (05)
b) State the causes of failure of foundation. (05)

OR

- Q.6 a) What qualities of bricks are essentially required from construction point of view? (05)
b) Mention the properties and uses of the following: (05)
i) Aluminum ii) Concrete

* * * * *